

Gross Power (SAE J1995)
365 HP (272kW) at 2,100 rpm

Net Power (SAE J1349)
359 HP (268kW) at 2,100 rpm

Bucket Capacity
1.46m³~2.32m³

Operating Weight
39,100kg

HX380AL

With EU Stage V Engine Installed



▲ HYUNDAI CONSTRUCTION EQUIPMENT

Head Office(Sales Office)

3F, Bundang First Tower, 55 Bundang-ro, Bundang-gu, Seongnam-si, Gyeonggi-do, 13591, Korea

Americas Operation : Hyundai Construction Equipment Americas, Inc.

6100 Atlantic Boulevard Norcross Ga 30071 U.S.A
TEL (1) 847-678-823-7802 FAX (1) 847-678-823-7778

Europe Operation : Hyundai Construction Equipment Europe N.V.

Hyundailaan 4,
3980 Tessenderlo, Belgium
TEL (32) 14-56-2200 FAX (32) 14-59-3405

PLEASE CONTACT

WHAT'S NEWEST AND BEST

HX380AL

THE BEST PRODUCTIVITY AND FUEL EFFICIENCY

- EU STAGE V Engine **NEW**
- Eco Report **NEW**
- IPC (Intelligent Power Control) **Upgrade**
- Fuel Rate Information
- Eco Gauge
- Automatic Engine Shutdown

NEW EXTERIOR DESIGN FOR ROBUSTNESS AND SAFETY

- Side Protector **Option**
- ROPS
FOG/FOPS **Option**
- Reinforced Durability of Upper and Lower Structure
and Attachments
- Durable Cooling Module
- Reinforced Pin, Bush and Polymer Shim
- Wear Resistant Cover Plate

EASY CONTROL AND COMFORTABLE OPERATION

- Visibility and Handle Improvement **NEW**
- Key On Init Work Mode **NEW**
- One Pedal Travel Straight **Option**
- Proportional Auxiliary Hydraulic System **Option**
- Integrated Audio System **Option**
- Intelligent & Wide Cluster
- Jog Dial Module
- OME (Owner Menu Editing)

THE ULTIMATE SAFE ENVIRONMENT

- Auto Safety Lock **NEW**
- AAVM **Option**
- Seatbelt Warning Alarm
- Cabin Suspension Mount

SERVICEABILITY AND TELEMATICS

- ECD (Engine Connected Diagnostics) **NEW**
- Hi MATE **Option**
- 2x Longer Lasting Filter (1000hr)
- Unnecessary Regular DPF Cleaning
Service Interval
- Mobile Fleet App.
- Connected Diagnostics





THE BEST PRODUCTIVITY AND FUEL EFFICIENCY

HX A Series is equipped with eco-friendly, high-performance engines that meet the EU Stage V emission requirements.

BETTER FUEL-EFFICIENCY
(Compared to HX Series)



ENVIRONMENTALLY FRIENDLY FUEL EFFICIENCY

Eco Report **NEW**

It reports the excavator's inefficient operation status and help improving operator's working habit.



Fuel Rate Information

Fuel information is displayed as average rate and latest fuel consumed for guiding to economy operating.



Eco Gauge

Gauge level changes in accordance with engine working load and color indicates fuel saving-operation status.



Automatic Engine Shutdown

Adjustable 'Automatic Engine Shutdown' significantly reduces idle time, overall operating hours and fuel consumption.



EU STAGE V CERTIFIED ENGINE

Cummins L9 engine is satisfying the most strict environmental emission regulation in the world (Reduction in PM 60%)

EU STAGE V Engine **NEW**

Now in its fourth decade of continuous improvement, the L9 for 2019 features an EGR-free design that delivers 5 percent more power and 10 percent more peak torque than the current model. Increased fuel economy and longer maintenance intervals contribute to a reduced cost of operation.

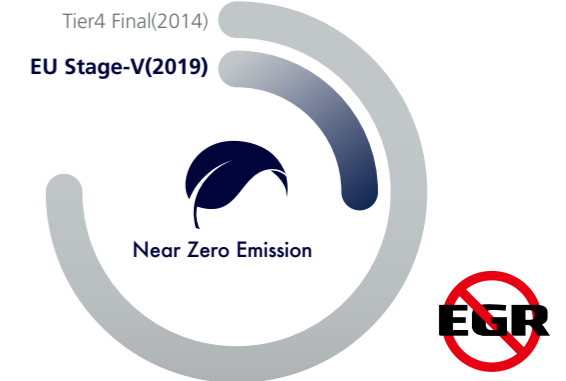

IPC (Intelligent Power Control) **Upgrade**

HX A Series adopts the upgraded IPC system. It is able to optimize pump flow rate and power at the various working condition through the individual pump control. Furthermore, optimized design of MCV and pipe line minimizes energy loss such as conflux and throttle loss.





NEW EXTERIOR DESIGN FOR ROBUSTNESS AND SAFETY

The true value of HX A Series lies in its durability and high productivity. The robust upper and lower frame structure can endure external shock and heavy work loads. Attachment performance has been proven through rigorous field testing. No matter how tough the working environment is, you can always rely on the HYUNDAI Excavator HX A Series.



1 Reinforced Pin, Bush and Polymer Shim

2 Wear Resistant Cover Plate



We make the best performance in rough working conditions without any unsureness with trustworthy HX380AL.



HX A Series is equipment with eco-friendly, high-performance engines that meet the EU Stage V emission requirement. Become a true leader on the ground with HX A Series.

ROPS / FOG Cabin

The cabin structure of Hyundai HX A Series is using integrally welded low-stress, high strength steel to meet ROPS and FOG certification.

- ROPS : Roll-Over Protective Structures ISO12117-2
- FOG : Falling Object Guard, ISO10262 Level2



Reinforced Durability of Upper and Lower Structure and Attachments

The upper and lower structure and attachments of HX A Series have higher durability than demanded on the site, as proven through numerous tests including road tests and virtual simulation. The wear resistance of the bucket has been improved by use of new material.

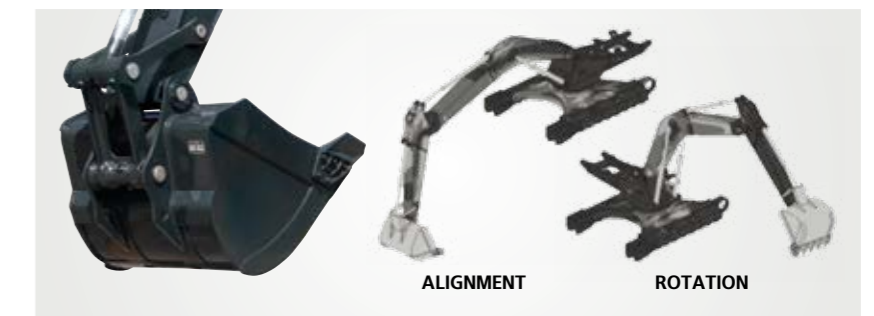

Durable Cooling Module

HX A Series has a durable cooling module that passed stringent tests, demonstrating the highest productivity in tough working environments.



Side Protector Option

Protect sides frame during operation in narrow area



13%

CABIN SPACE FOR DRIVERS INCREASED BY



310mm
340mm



EASY CONTROL AND COMFORTABLE OPERATION

Many electronic functions are concentrated in the most convenient spot for operators to improve work efficiency. The highly-advanced infotainment system, a product of HCE's intensive information technology development, enables both productivity and comfort while working! HX A Series is designed with the operator in mind.

Intelligent & Wide Cluster

The 8" capacitive-type display (like smart-phone display) of HX A Series is delivering excellent legibility. The centralized switches on the display allow convenience of checking the urea level and temperature outside the cabin.

One Pedal Travel Straight **Option**

One Pedal straight Travel is available for customers' convenience when long distance traveling or combination of attachment work with traveling is necessary.



Proportional Auxiliary Hydraulic System **Option**

Proportional control switch with better speed control helps operators to enlarge the operation convenience whenever they do time-consuming work.

Jog Dial Module

The integrated jog dial module applies to the accelerator, remote air conditioner controller and operation of the cluster, allowing convenient operation. In the event of failure of the jog dial module, the emergency mode is activated on the cluster to ensure fail-safe function.



Visibility and Handle Improvement **NEW**

Visibility through cabin door is improved and handle design on the cabin door is also improved and offers better convenient while operator get on and off the cabin.



Key On Init Work Mode **NEW**

Operator can maintain previously set about attachment mode when starting.



Integrated Audio System **Option**

The radio player with a USB-based MP3 player, an integrated Bluetooth hands-free feature, and a built-in microphone allow for phone calls while at work and in transit. The radio player is conveniently located on the right side of the operator to allow for improved access.



OME(Owner Menu Editing)

The Owner of machine can restrict operators access the set of functions. In the menu, Owner can set the list of the function to lock or unlock it. It is necessary to input the password to access the set of function.

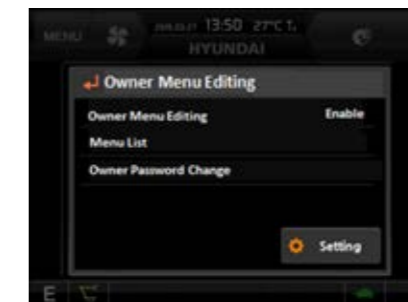

// HX380AL with advanced technology ensures our safety on a construction site. //



HX A Series excavators are products of HCE's spirit of initiative, creativity, and strong drive. HCE engineers, who are the best in the industry, have worked tirelessly to offer a zero-defect product. The new HX A Series reflects customers' needs in the field gleaned by thorough monitoring.

Auto Safety Lock **NEW**

It prevents unintended operation. If operator unlock safety lever when RCV lever is pressed, excavator is not controlled by RCV lever.

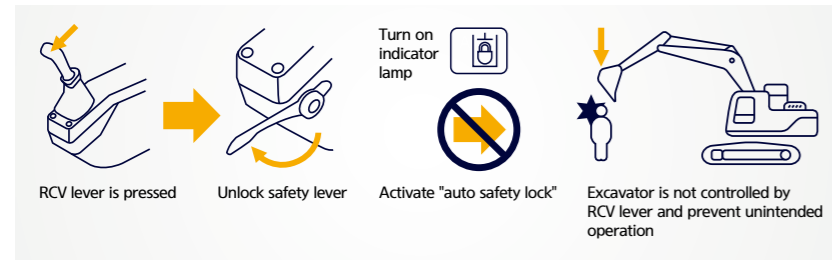

AAVM(Advanced Around View Monitoring) Camera System **Option**

HX A Series has a state-of-the-art AAVM video camera system to secure field of vision for operators in all directions, thereby preventing accidents. Operators can easily check the workplace in the front and rear and to the right and left.

- **AAVM**(Advanced Around View Monitoring) : Secure field of vision in all directions by nine views including 3D bird's eye view and 2D/4CH view.
- **IMOD**(Intelligent Moving Object Detection) : Inform when people or dangerous objects are detected within the range of operation(recognition distance : 5 m).



Seatbelt Warning Alarm

If the seatbelt is not buckled when the ignition key is turned, an alarm is triggered in intervals along with a continuous visual alert. This emphasizes our priority for operator safety.

Cabin Suspension Mount

With a low-vibration design by the coil spring and damper inside the mount, the cab suspension mount of HX A Series reduces noise inside the cabin and improves durability, providing a comfortable operation space that lessens operators' fatigue.



THE ULTIMATE SAFE ENVIRONMENT

The true value of HX A Series lies in its durability. The robust frame structure and the attachments show the real value of HX A Series in tough working environments and promise higher productivity.

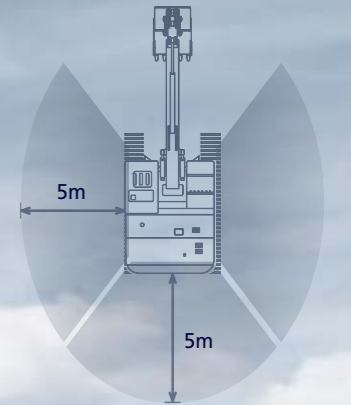

*Photo may include optional equipment.



SERVICEABILITY AND TELEMATICS

IoT / ICT / AI-based digital technology.
Creating a smart construction site. Maximizes connectivity, productivity, and safety for successful businesses.



Hi MATE

Option

IT'S CONVENIENT, EASY AND VALUABLE

Hi MATE Hyundai's newly developed remote management system, utilizes GPS-satellite technology to provide customers with the highest level of service and product support available. Hi MATE enables users to remotely evaluate machine performance, access diagnostic information, and verify machine locations at the touch of a button.

WHAT IS BENEFITS



Increase Productivity

It helps you operate machines in efficient. You can check the difference between total engine hours and actual working hours. See how productive your machines are and plan any required cost saving solutions. Hi MATE offers working information such as working / idling hours, fuel consumption and rate.



Convenient and Easy Monitoring

There is nothing much to do to monitor your machines. Just log on to the Hi MATE website or mobile application. Hi MATE allows you to watch your machines whenever and wherever you are.



Security

Protect your machines from theft or unauthorized usage with Hi MATE. If the machine moves out of the Geofence boundary, you will get alerts.

ECD(Engine Connected Diagnostics) **NEW**

It supports service technician with remote diagnostics report and ensure it arrive on site with proper tools after preparing in advance.

We are all connected

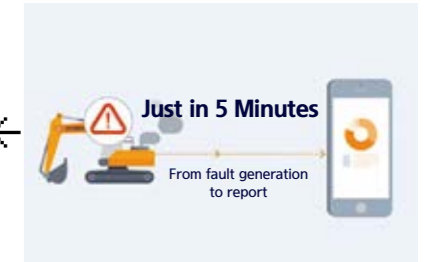
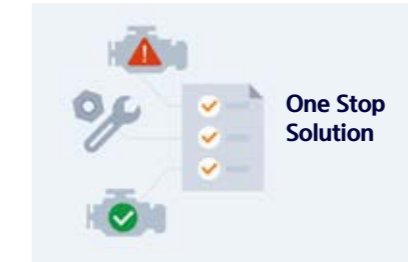

2x Longer Lasting Filter (1,000hr)

The service interval of engine-oil, engine-oil filter and fuel filters have been increased from 500 hours to 1,000 hours

Unnecessary Regular DPF Cleaning Service Interval

Regular ash cleaning for DPF is not necessary, only needed as indicated by fault-indicator lamp.

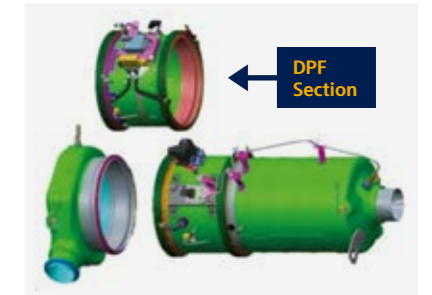

Mobile Fleet App.

The new Mobile App is optimized to fleet management. It provides productivity, health insights based on telematics technology and enables fleet owner just focus on most wanted equipment in view of economical usage, utilization, fault codes and maintenance. The new Mobile App sorts equipment in order of eco-index, utilization-index and fault code level automatically so that urgent equipment pops up automatically.

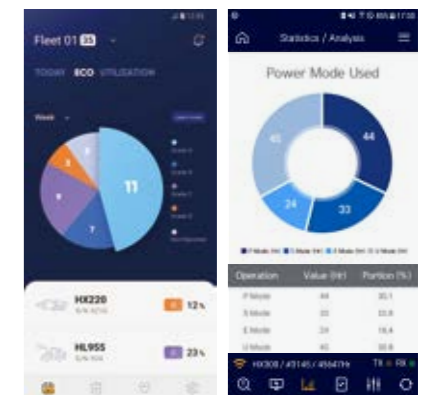

Hi MATE Fleet App HCE-DT AIR App

Connected Diagnostics

HCE-DT Air connect you and your equipment wirelessly via smartphone and laptop right on site. You can diagnose root causes and troubleshoot for fault codes through the connection. Engine connected diagnostics is a kind of cooperated remote diagnostics service between Cummins cloud and Hi MATE cloud. It enables you get engine diagnostics report by cloud based fault code analysis in real-time and prepare parts, tools necessary in advance. It will help increase first visit fix rates.

SPECIFICATIONS

ENGINE

Maker / Model	Cummins / L9
Type	6 cylinder, water cooled, 4-cycle, turbocharged, charge air cooled, direct injection, electronic controlled diesel engine
Gross Power (SAE J1995)	365 HP (272kW) at 2,100 rpm
Net Power (SAE J1349)	359 HP (268kW) at 2,100 rpm
Max. Power	380 HP (283kW) at 1,800 rpm
Max. Torque	1,795 N · m (1,324 lb-ft) at 1,400 rpm
Piston Displacement	8,900 cc (543 cu in)

HYDRAULIC SYSTEM

MAIN PUMP

Type	Variable displacement tandem axial piston pumps
Max. Flow	2x340 lpm (89.8U.S.gpm/74.8U.K.gpm)
Sub-Pump For Pilot Circuit	Gear pump

Cross-sensing and fuel saving pump system.

HYDRAULIC MOTORS

Travel	Variable displacement axial piston motor
Swing	Axial piston motor

RELIEF VALVE SETTING

Implement Circuits	330kgf/cm ² (4,693psi)
Travel	360kgf/cm ² (5,120psi)
Power Boost (Boom, Arm, Bucket)	360kgf/cm ² (5,120psi)
Swing Circuit	290kgf/cm ² (4,125psi)
Pilot Circuit	40 kgf/cm ² (570 psi)
Service Valve	Installed

HYDRAULIC CYLINDERS

No. of Cylinder	Boom : Ø160x1500 mm
Bore X Stroke	Arm : Ø170x1760 mm
	Bucket : Ø150x1295 mm

DRIVES & BRAKES

Drive Method	Fully hydrostatic type
Drive Motor	Axial piston motor, in-shoe design
Reduction System	Planetary reduction gear
Max. Drawbar Pull	32,517kgf(71,688lbf)
Max. Travel Speed (High / Low)	5.7km/hr(3.5mph) / 3.5km/hr(2.2mph)
Gradeability	35° (70%)
Parking Brake	Multi wet disc

CONTROL

Pilot pressure operated joysticks and pedals with detachable lever provide almost effortless and fatigueless operation.

Pilot Control	Two joysticks with one safety lever (LH) : Swing and arm, Boom and bucket
Traveling and Steering	Two levers with pedals
Engine Throttle	Electric, dial type

SWING SYSTEM

Swing Motor	Fixed displacement axial piston motor
Swing Reduction	Planetary gear reduction
Swing Bearing Lubrication	Grease-bathed
Swing Brake	Multi wet disc
Swing Speed	10.4 rpm

COOLANT & LUBRICANT CAPACITY

	liter	US gal	UK gal
Fuel Tank	600	158.5	131.9
Engine Coolant	55	14.5	9.3
Engine Oil	30	7.9	6.6
Swing Device	8	2.1	2.4
Final Drive (Each)	5.5	1.5	1.72
Hydraulic System (Including Tank)	414	109.4	91.06
Hydraulic Tank	210	55.5	46.2
Def/Adblue®	70	18.5	15.5

UNDERCARRIAGE

The X-leg type center frame is integrally welded with reinforced box-section track frames. The undercarriage includes lubricated rollers, idlers, track adjusters with shock absorbing springs and sprockets, and a track chain with double or triple grouser shoes.

Center Frame	X - Leg Type
Track Frame	Pentagonal Box Type
No. of Shoes on Each Side	48 EA
No. of Carrier Roller on Each Side	2 EA
No. of Track Roller on Each Side	9 EA
No. of Rail Guard on Each Side	2 EA

OPERATING WEIGHT (APPROXIMATE)

Operating weight, including 6,500mm(21' 4") boom, 3,200mm(10' 6") arm, SAE heaped 1.62m³(2.12 yd³) bucket, lubricant, coolant, full fuel tank, full hydraulic tank, and all standard equipments.

OPERATING WEIGHT

Shoes	Type	Width mm(in)	Operating Weight		Ground Pressure
			kg (lb)	kgf/cm ² (psi)	
Triple Grouser	600 (24")	600 (24")	HX380AL	39,100 (86,200)	0.70 (9.97)
			NL	38,890 (85,737)	0.70 (9.92)
	700 (28")	700 (28")	HX380AL	39,550 (87,193)	0.61 (8.64)
			HX380AL	40,000 (88,185)	0.54 (7.65)
900 (36")	900 (36")	HX380AL	40,460 (89,199)	0.48 (6.88)	
		HX380AL	39,520 (87,127)	0.71 (10.07)	

AIR CONDITIONING SYSTEM

The air condition system for the machine contains the fluorinated greenhouse gas with global warming potential of R134a. (Global Warming Potential : 1,430) The system hold 0.8 kg refrigerant consisting of a CO₂ equivalent of 1.14 metric tonnes. For more information, Please refer to the manual.

DIMENSIONS & WORKING RANGE

HX380AL / HX380A NL DIMENSIONS

6.15 m (20' 2") / 6.5 m (21' 4"), BOOM and 2.5 m (8' 2"), 3.2 m (10' 6"), 3.9 m (12' 10") ARM

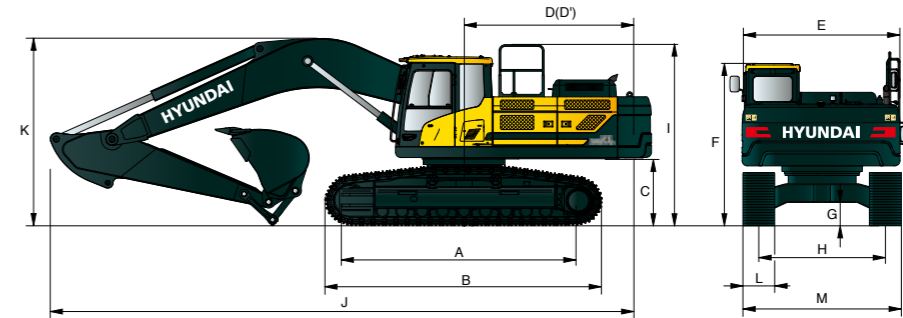

Unit : mm (ft-in)

A Tumbler Distance	4,340 (14' 3")
B Overall Length of Crawler	5,270 (17' 3")
C Ground Clearance of Counter Weight	1,295 (4' 3")
D Tail Swing Radius	3,620 (11' 11")
D' Rear-End Length	3,555 (11' 8")
E Overall Width of Upper Structure	2,980 (9' 9")
F Overall Height of Cab	3,240 (10' 8")
G Min. Ground Clearance	550 (1' 10")
H Track gauge	HX380AL 2,740 (9' 0") HX380A NL 2,390 (7' 10")
I Overall Height of Guardrail w/ Grouser	3,470 (11' 5")

Boom Length	6,150 (20' 2")	6,500 (21' 4")				
Arm Length	2,500 (8' 2")	2,500 (8' 2")	3,200 (10' 6")	3,900 (12' 10")		
J Overall Length	11,100 (36' 5")	11,450 (37' 7")	11,400 (37' 5")	11,400 (37' 5")		
K Overall Height of Boom	3,830 (12' 7")	3,740 (12' 3")	3,630 (11' 11")	3,740 (12' 3")		
L Track Shoe Width	600 (1' 12")	600 (1' 12")	700 (2' 4")	800 (2' 7")	900 (2' 11")	
M Overall Width w/o Additional Foot Board	HX 380AL	3,340 (10' 11")	3,340 (10' 11")	3,440 (11' 3")	3,540 (11' 7")	3,640 (11' 11")
	HX 380A NL	2,990 (9' 10")	2,990 (9' 10")	-	-	-

HX380AL / HX380A NL WORKING RANGE

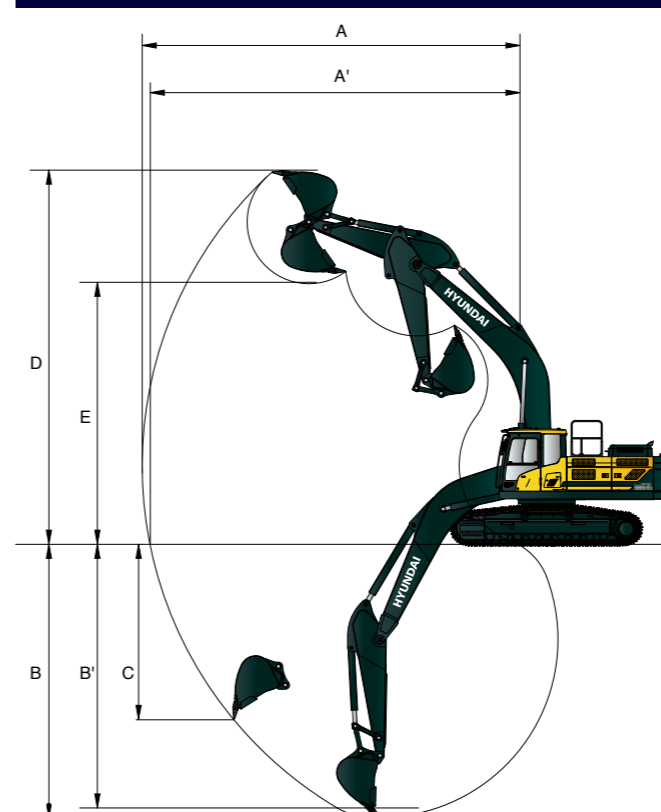

Unit : mm (ft-in)











Boom length	6,150 (20' 2")	6,500 (21' 4")		
Arm length	2,500 (8' 2")	2,500 (8' 2")	3,200 (10' 6")	3,900 (12' 10")
A Max. digging reach	10,300 (33' 10")	10,650 (34' 11")	11,160 (36' 7")	11,820 (38' 9")
A' Max. digging reach on ground	10,060 (33' 0")	10,410 (34' 2")	10,930 (35' 10")	11,620 (38' 1")
B Max. digging depth	6,560 (21' 6")	6,820 (22' 5")	7,520 (24' 8")	8,220 (27' 0")
B' Max. digging depth (8' level)	6,380 (20' 11")	6,640 (21' 9")	7,360 (24' 2")	8,080 (26' 6")
C Max. vertical wall digging depth	4,780 (15' 8")	5,030 (16' 6")	5,480 (28' 0")	6,300 (20' 8")
D Max. digging height	10,000 (32' 10")	10,330 (33' 11")	10,270 (33' 8")	10,610 (34' 10")
E Max. dumping height	6,870 (22' 6")	7,190 (23' 7")	7,190 (23' 7")	7,500 (24' 7")
F Min. swing radius	4,310 (14' 2")	4,490 (14' 9")	4,490 (14' 9")	4,350 (14' 3")

LIFTING CAPACITY











 Rating over-front
  Rating over-side or 360 degree

HX380AL

6.15 m (20' 2") boom, 2.5 m (8' 2") arm equipped with 600mm(24") Triple grouser shoe.

Lift-point height (m/ft)		Lift-point radius								At max. reach		
		3.0m (9.8ft)		4.5m (14.8ft)		6.0m (19.7ft)		7.5m (24.6ft)		Capacity		Reach
												m (ft)
7.5m	kg					*9,240	*9,240			*9,470	*9,470	6.71
24.6ft	lb					*20,370	*20,370			*20,880	*20,880	(22.0)
6.0m	kg					*9,720	*9,720	*9,360	7,940	*9,400	7,600	7.69
19.7ft	lb					*21,430	*21,430	*20,640	17,500	*20,720	16,760	(25.2)
4.5m	kg			*14,000	*14,000	*11,060	10,960	*9,770	7,760	*9,530	6,610	8.27
14.8ft	lb			*30,860	*30,860	*24,380	24,160	*21,540	17,110	*21,010	14,570	(27.1)
3.0m	kg					*12,720	10,380	*10,540	7,500	*9,770	6,130	8.55
9.8ft	lb					*28,040	22,880	*23,240	16,530	*21,540	13,510	(28.1)
1.5m	kg					*14,120	9,910	*11,290	7,250	9,800	6,000	8.56
4.9ft	lb					*31,130	21,850	*24,890	15,980	21,610	13,230	(28.1)
0.0m	kg			*20,360	14,680	*14,840	9,650	*11,690	7,090	10,180	6,200	8.29
0.0ft	lb			*44,890	32,360	*32,720	21,270	*25,770	15,630	22,440	13,670	(27.2)
-1.5m	kg	*14,540	*14,540	*19,660	14,710	*14,710	9,590	*11,390	7,090	*10,910	6,830	7.72
-4.9ft	lb	*32,060	*32,060	*43,340	32,430	*32,430	21,140	*25,110	15,630	*24,050	15,060	(25.3)
-3.0m	kg	*24,010	*24,010	*17,760	14,950	*13,350	9,750			*11,280	8,310	6.77
-9.8ft	lb	*52,930	*52,930	*39,150	32,960	*29,430	21,500			*24,870	18,320	(22.2)
-4.5m	kg			*13,520	*13,520					*11,150	*11,150	5.23
-14.8ft	lb			*29,810	*29,810					*24,580	*24,580	(17.2)

6.5 m (21' 4") boom, 2.5 m (8' 2") arm equipped with 600mm(24") Triple grouser shoe.

Lift-point height (m/ft)		Lift-point radius								At max. reach		
		3.0m (9.8ft)		4.5m (14.8ft)		6.0m (19.7ft)		7.5m (24.6ft)		Capacity		Reach
												m (ft)
7.5m	kg									*8,970	8,610	7.16
24.6ft	lb									*19,780	18,980	(23.5)
6.0m	kg					*9,570	*9,570	*8,920	7,920	*8,920	6,950	8.08
19.7ft	lb					*21,100	*21,100	*19,670	17,460	*19,670	15,320	(26.5)
4.5m	kg			*14,460	*14,460	*11,020	10,780	*9,500	7,680	*9,030	6,110	8.64
14.8ft	lb			*31,880	*31,880	*24,290	23,770	*20,940	16,930	*19,910	13,470	(28.3)
3.0m	kg					*12,690	10,160	*10,330	7,380	*9,240	5,680	8.91
9.8ft	lb					*27,980	22,400	*22,770	16,270	*20,370	12,520	(29.2)
1.5m	kg					*14,020	9,690	*11,090	7,110	9,120	5,560	8.91
4.9ft	lb					*30,910	21,360	*24,450	15,670	20,110	12,260	(29.2)
0.0m	kg			*14,720	14,400	*14,660	9,450	*11,510	6,950	9,450	5,730	8.66
0.0ft	lb			*32,450	31,750	*32,320	20,830	*25,380	15,320	20,830	12,630	(28.4)
-1.5m	kg			*19,240	14,470	*14,510	9,400	*11,360	6,920	*10,230	6,260	8.12
-4.9ft	lb			*42,420	31,900	*31,990	20,720	*25,040	15,260	*22,550	13,800	(26.6)
-3.0m	kg	*22,870	*22,870	*17,520	14,710	*13,390	9,540			*10,550	7,460	7.22
-9.8ft	lb	*50,420	*50,420	*38,620	32,430	*29,520	21,030			*23,260	16,450	(23.7)
-4.5m	kg			*14,070	*14,070					*10,500	10,480	5.80
-14.8ft	lb			*31,020	*31,020					*23,150	23,100	(19.0)



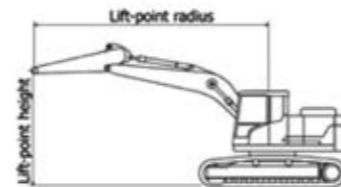











- 1 | Lifting capacity are based on ISO 10567.
- 2 | Lifting capacity of HX Series does not exceed 75% of tipping load with the machine on firm, level ground or 87% of full hydraulic capacity.
- 3 | The Lift-point is bucket pivot mounting pin on the arm (without bucket mass).
- 4 | (*) indicates load limited by hydraulic capacity.

















 Rating over-front
  Rating over-side or 360 degree

HX380AL

6.5 m (21' 4") boom, 3.2 m (10' 6") arm equipped with 600mm(24") Triple grouser shoe.

Lift-point height (m/ft)		Lift-point radius										At max. reach								
		1.5m (4.9ft)		3.0m (9.8ft)		4.5m (14.8ft)		6.0m (19.7ft)		7.5m (24.6ft)		9.0m (29.5ft)		Capacity		Reach				
																m (ft)				
7.5m	kg													*7,790	*7,790		*7,050	*7,050	7.80	
24.6ft	lb													*17,170	*17,170		*15,540	*15,540	(25.6)	
6.0m	kg													*8,000	*8,000		*6,910	6,290	8.64	
19.7ft	lb													*17,640	*17,640		*15,230	13,870	(28.4)	
4.5m	kg							*12,530	*12,530	*9,960	*9,960	*8,720	7,770	*8,150	5,760		*7,020	5,580	9.17	
14.8ft	lb							*27,620	*27,620	*21,960	*21,960	*19,220	17,130	*17,970	12,700		*15,480	12,300	(30.1)	
3.0m	kg					*16,270	15,710	*11,750	10,320	*9,660	7,420	*8,570	5,600	*7,360	5,200		*7,360	5,200	9.42	
9.8ft	lb					*35,870	34,630	*25,900	22,750	*21,300	16,360	*18,890	12,350	*16,230	11,460		*16,230	11,460	(30.9)	
1.5m	kg					*17,950	14,680	*13,320	9,750	*10,570	7,110	8,960	5,440	*7,970	5,070		*7,970	5,070	9.43	
4.9ft	lb					*39,570	32,360	*29,370	21,500	*23,300	15,670	19,750	11,990	*17,570	11,180		*17,570	11,180	(30.9)	
0.0m	kg					*18,930	14,280	*14,290	9,390	*11,200	6,880	8,840	5,330	8,580	5,180		8,580	5,180	9.19	
0.0ft	lb					*41,730	31,480	*31,500	20,700	*24,690	15,170	19,490	11,750	18,920	11,420		18,920	11,420	(30.1)	
-1.5m	kg					*12,410	*12,410	*19,670	14,220	*14,520	9,260	*11,370	6,780		9,280	5,580		9,280	5,580	8.68
-4.9ft	lb					*27,360	*27,360	*43,360	31,350	*32,010	20,410	*25,070	14,950		20,460	12,300		20,460	12,300	(28.5)
-3.0m	kg	*15,020	*15,020	*20,150	*20,150	*18,480	14,370	*13,910	9,310	*10,750	6,850				*10,070	6,460		*10,070	6,460	7.85
-9.8ft	lb	*33,110	*33,110	*44,420	*44,420	*40,740	31,680	*30,670	20,530	*23,700	15,100				*22,200	14,240		*22,200	14,240	(25.7)
-4.5m	kg			*21,800	*21,800	*15,950	14,760	*11,940	9,590						*10,520	8,480		*10,520	8,480	6.57
-14.8ft	lb			*48,060	*48,060	*35,160	32,540	*26,320	21,140						*23,190	18,700		*23,190	18,700	(21.6)

6.5 m (21' 4") boom, 3.9 m (12' 10") arm equipped with 600mm(24") Triple grouser shoe.

Lift-point height (m/ft)		Lift-point radius										At max. reach							
		1.5m (4.9ft)		3.0m (9.8ft)		4.5m (14.8ft)		6.0m (19.7ft)		7.5m (24.6ft)		9.0m (29.5ft)		Capacity		Reach			
																m (ft)			
9.0m	kg																*5,580	*5,580	7.43
29.5ft	lb																*12,300	*12,300	(24.4)
7.5m	kg																*6,800	*6,800	8.59
24.6ft	lb																*14,990	*14,990	(28.2)
6.0m	kg																*7,180	*7,180	9.36
19.7ft	lb																*15,830	*15,830	(30.7)
4.5m	kg									*8,930	*8,930	*7,990	7,950	*7,510	5,900		*5,200	5,030	9.85
14.8ft	lb									*19,690	*19,690	*17,610	17,530	*16,560	13,010		*11,460	11,090	(32.3)
3.0m	kg					*14,540	*14,540	*10,830	10,620	*9,040	7,580	*8,060	5,700	*5,420	4,720		*5,420	4,720	10.08
9.8ft	lb					*32,060	*32,060	*23,880	23,410	*19,930	16,710	*17,770	12,570	*11,950	10,410		*11,950	10,410	(33.1)
1.5m	kg		</																

LIFTING CAPACITY

Rating over-front Rating over-side or 360 degree

HX380A NL

6.5 m (21' 4") boom, 2.5 m (8' 2") arm equipped with 600mm(24") Triple grouser shoe.

Lift-point height (m/ft)		Lift-point radius								At max. reach		
		3.0m (9.8ft)		4.5m (14.8ft)		6.0m (19.7ft)		7.5m (24.6ft)		Capacity	Reach	
												m (ft)
7.5m	kg									*8,970	7,470	7.16
24.6ft	lb									*19,780	16,470	(23.5)
6.0m	kg					*9,570	*9,570	*8,920	6,860	*8,920	6,020	8.08
19.7ft	lb					*21,100	*21,100	*19,670	15,120	*19,670	13,270	(26.5)
4.5m	kg			*14,460	14,130	*11,020	9,290	*9,500	6,630	*9,030	5,260	8.64
14.8ft	lb			*31,880	31,150	*24,290	20,480	*20,940	14,620	*19,910	11,600	(28.3)
3.0m	kg					*12,690	8,690	*10,330	6,340	9,190	4,880	8.91
9.8ft	lb					*27,980	19,160	*22,770	13,980	20,260	10,760	(29.2)
1.5m	kg					*14,020	8,240	*11,090	6,080	9,050	4,760	8.91
4.9ft	lb					*30,910	18,170	*24,450	13,400	19,950	10,490	(29.2)
0.0m	kg			*14,720	12,010	*14,660	8,000	*11,510	5,920	9,370	4,890	8.66
0.0ft	lb			*32,450	26,480	*32,320	17,640	*25,380	13,050	20,660	10,780	(28.4)
-1.5m	kg			*19,240	12,070	*14,510	7,960	*11,360	5,900	*10,230	5,350	8.12
-4.9ft	lb			*42,420	26,610	*31,990	17,550	*25,040	13,010	*22,550	11,790	(26.6)
-3.0m	kg	*22,870	*22,870	*17,520	12,300	*13,390	8,090			*10,550	6,370	7.22
-9.8ft	lb	*50,420	*50,420	*38,620	27,120	*29,520	17,840			*23,260	14,040	(23.7)
-4.5m	kg			*14,070	12,770					*10,500	8,930	5.80
-14.8ft	lb			*31,020	28,150					*23,150	19,690	(19.0)

6.5 m (21' 4") boom, 3.2 m (10' 6") arm equipped with 600mm(24") Triple grouser shoe.

Lift-point height (m/ft)		Lift-point radius						At max. reach				
		1.5m (4.9ft)	3.0m (9.8ft)	4.5m (14.8ft)	6.0m (19.7ft)	7.5m (24.6ft)	9.0m (29.5ft)	Capacity	Reach			
										m (ft)		
7.5m	kg					*7,790	7,100			*7,050	6,610	7.80
24.6ft	lb					*17,170	15,650			*15,540	14,570	(25.6)
6.0m	kg					*8,000	6,990			*6,910	5,440	8.64
19.7ft	lb					*17,640	15,410			*15,230	11,990	(28.4)
4.5m	kg			*12,530	*12,530	*9,960	9,490	*8,720	6,720	*8,150	4,960	9.17
14.8ft	lb			*27,620	*27,620	*21,960	20,920	*19,220	14,820	*17,970	10,930	(30.1)
3.0m	kg			*16,270	13,240	*11,750	8,830	*9,660	6,380	*8,570	4,810	9.42
9.8ft	lb			*35,870	29,190	*25,900	19,470	*21,300	14,070	*18,890	10,600	(30.9)
1.5m	kg			*17,950	12,270	*13,320	8,290	*10,570	6,070	8,890	4,650	9.43
4.9ft	lb			*39,570	27,050	*29,370	18,280	*23,300	13,380	19,600	10,250	(30.9)
0.0m	kg			*18,930	11,880	*14,290	7,950	*11,200	5,850	8,760	4,540	9.19
0.0ft	lb			*41,730	26,190	*31,500	17,530	*24,690	12,900	19,310	10,010	(30.1)
-1.5m	kg			*12,410	*12,410	*19,670	11,830	*14,520	7,810	*11,370	5,760	
-4.9ft	lb			*27,360	*27,360	*43,360	26,080	*32,010	17,220	*25,070	12,700	
-3.0m	kg	*15,020	*15,020	*20,150	*20,150	*18,480	11,970	*13,910	7,860	*10,750	5,820	
-9.8ft	lb	*33,110	*33,110	*44,420	*44,420	*40,740	26,390	*30,670	17,330	*23,700	12,830	
-4.5m	kg			*21,800	*21,800	*15,950	12,340	*11,940	8,140			
-14.8ft	lb			*48,060	*48,060	*35,160	27,210	*26,320	17,950			

- I 1 | Lifting capacity are based on ISO 10567.
- I 2 | Lifting capacity of HX Series does not exceed 75% of tipping load with the machine on firm, level ground or 87% of full hydraulic capacity.
- I 3 | The Lift-point is bucket pivot mounting pin on the arm(without bucket mass).
- I 4 | (*) indicates load limited by hydraulic capacity.

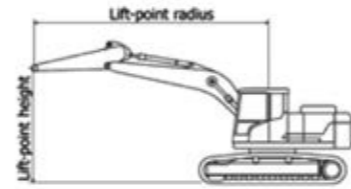

Rating over-front Rating over-side or 360 degree

HX380A NL

6.5 m (21' 4") boom, 3.9 m (12' 10") arm equipped with 600mm(24") Triple grouser shoe.

Lift-point height (m/ft)		Lift-point radius						At max. reach				
		1.5m (4.9ft)	3.0m (9.8ft)	4.5m (14.8ft)	6.0m (19.7ft)	7.5m (24.6ft)	9.0m (29.5ft)	Capacity	Reach			
										m (ft)		
9.0m	kg									*5580	*5580	7.43
29.5ft	lb									*12300	*12300	(24.4)
7.5m	kg							*6800	*6800			8.59
24.6ft	lb							*14990	*14990			(28.2)
6.0m	kg							*7180	*7180	*6500	5220	9.36
19.7ft	lb							*15830	*15830	*14330	11510	(30.7)
4.5m	kg							*8930	*8930	*7990	6890	9.85
14.8ft	lb							*19690	*19690	*17610	15190	(32.3)
3.0m	kg					*14540	13890	*10830	9120	*9040	6540	10.08
9.8ft	lb					*32060	30620	*23880	20110	*19930	14420	(33.1)
1.5m	kg					*17770	12700	*12620	8500	*10080	6190	10.09
4.9ft	lb					*39180	28000	*27820	18740	*22220	13650	(33.1)
0.0m	kg			*7060	*7060	*19500	12070	*13900	8070	*10910	5920	9.87
0.0ft	lb			*15560	*15560	*42990	26610	*30640	17790	*24050	13050	(32.4)
-1.5m	kg	*7760	*7760	*11450	*11450	*19920	11850	*14490	7850	*11330	5760	9.39
-4.9ft	lb	*17110	*17110	*25240	*25240	*43920	26120	*31940	17310	*24980	12700	(30.8)
-3.0m	kg	*12390	*12390	*16990	*16990	*19280	11880	*14310	7810	*11160	5740	
-9.8ft	lb	*27320	*27320	*37460	*37460	*42510	26190	*31550	17220	*24600	12650	
-4.5m	kg	*17960	*17960	*24770	23970	*17460	12130	*13090	7960			
-14.8ft	lb	*39590	*39590	*54610	52840	*38490	26740	*28860	17550			
-6.0m	kg			*18940	*18940	*13630	12670					
-19.7ft	lb			*41760	*41760	*30050	27930					

6.15 m (20' 2") boom, 2.5 m (8' 2") arm equipped with 600mm(24") Triple grouser shoe.

Lift-point height (m/ft)		Lift-point radius				At max. reach						
		3.0m (9.8ft)	4.5m (14.8ft)	6.0m (19.7ft)	7.5m (24.6ft)	Capacity	Reach					
								m (ft)				
7.5m	kg			*9,240	*9,240			*9,470	8,350	6.71		
24.6ft	lb			*20,370	*20,370			*20,880	18,410	(22.0)		
6.0m	kg			*9,720	*9,720	*9,360	6,890	*9,400	6,590	7.69		
19.7ft	lb			*21,430	*21,430	*20,640	15,190	*20,720	14,530	(25.2)		
4.5m	kg			*14,000	*14,000	*11,060	9,460	*9,770	6,720	8.27		
14.8ft	lb			*30,860	*30,860	*24,380	20,860	*21,540	14,820	(27.1)		
3.0m	kg					*12,720	8,900	*10,540	6,460	*9,770	5,280	8.55
9.8ft	lb					*28,040	19,620	*23,240	14,240	*21,540	11,640	(28.1)
1.5m	kg					*14,120	8,450	*11,290	6,220	9,720	5,150	8.56
4.9ft	lb					*31,130	18,630	*24,890	13,710	21,430	11,350	(28.1)
0.0m	kg					*20,360	12,280	*14,840	8,200	*11,690	6,070	8.29
0.0ft	lb					*44,890	27,070	*32,720	18,080	*25,770	13,380	(27.2)
-1.5m	kg	*14,540	*14,540	*19,660	12,310	*14,710	8,150	*11,390	6,060	*10,910	5,850	7.72
-4.9ft	lb	*32,060	*32,060	*43,340	27,140	*32,430	17,970	*25,110	13,360	*24,050	12,900	(25.3)
-3.0m	kg	*24,010	*24,010	*17,760	12,540	*13,350	8,300			*11,280	7,110	6.77
-9.8ft	lb	*52,930	*52,930	*39,150	27,650	*29,430	18,300			*24,870	15,670	(22.2)
-4.5m	kg			*13,520	13,080					*11,150	10,580	5.23
-14.8ft	lb			*29,810	28,840					*24,580	23,320	(17.2)

- I 1 | Lifting capacity are based on ISO 10567.
- I 2 | Lifting capacity of HX Series does not exceed 75% of tipping load with the machine on firm, level ground or 87% of full hydraulic capacity.
- I 3 | The Lift-point is bucket pivot mounting pin on the arm(without bucket mass).
- I 4 | (*) indicates load limited by hydraulic capacity.

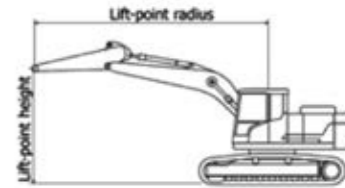

BUCKET SELECTION GUIDE & DIGGING FORCE

BUCKETS

All buckets are welded with high-strength steel.

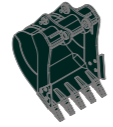
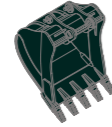
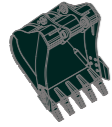

	GP	HD	Rock-HD
SAE heaped m ³ (yd ³)	1.46	1.46	1.46
	1.62	1.62	1.62
	1.90	1.90	1.90
	2.10	2.10	
	2.32		

Capacity m ³ (yd ³)		Weight mm (in)	Weight kg (lb)	Tooth EA	Recommendation mm (ft-in)			
SAE heaped	CECE heaped				6,150 (20' 2") Boom	6,500 (21' 4") Boom		
					2,500 (8' 2") Arm	2,500 (8' 2") Arm	3,200 (10' 6") Arm	3,900 (12' 10") Arm
◆ 1.46 (1.91)	1.28 (1.67)	1,305 (51.4")	1,400 (3,090)	4	●	●	●	●
◆ 1.62 (2.12)	1.42 (1.86)	1,415 (55.7")	1,500 (3,310)	5	●	●	●	◐
◆ 1.90 (2.49)	1.65 (2.16)	1,600 (63.0")	1,610 (3,550)	5	●	●	◐	■
◆ 2.10 (2.75)	1.84 (2.41)	1,735 (68.3")	1,690 (3,730)	5	●	◐	■	▲
◆ 2.32 (3.03)	2.02 (2.64)	1,885 (74.2")	1,800 (3,970)	6	◐	■	■	▲
◆ 1.46 (1.91)	1.28 (1.67)	1,305 (51.4")	1,560 (3,440)	4	●	●	●	●
◆ 1.62 (2.12)	1.42 (1.86)	1,415 (55.7")	1,660 (3,660)	5	●	●	●	◐
◆ 1.90 (2.49)	1.65 (2.16)	1,600 (63.0")	1,790 (3,950)	5	●	●	◐	■
◆ 2.10 (2.75)	1.84 (2.41)	1,735 (68.3")	1,880 (4,140)	5	◐	◐	■	▲
★ 1.46 (1.91)	1.28 (1.67)	1,305 (51.4")	1,750 (3,860)	4	●	●	●	◐
★ 1.62 (2.12)	1.42 (1.86)	1,415 (55.7")	1,850 (4,080)	5	●	●	●	◐
★ 1.90 (2.49)	1.65 (2.16)	1,600 (63.0")	1,990 (4,390)	6	●	◐	■	■

- ◆ General Purpose
- ◆ Rock-Heavy duty bucket
- ★ Heavy duty bucket
- : Applicable for materials with density of 2,100 kgf/m³ (3,500 lbf/yd³) or less
- ◐ : Applicable for materials with density of 1,800 kgf/m³ (3,000 lbf/yd³) or less
- : Applicable for materials with density of 1,500 kgf/m³ (2,500 lbf/yd³) or less
- ▲ : Applicable for materials with density of 1,200 kgf/m³ (2,000 lbf/yd³) or less

ATTACHMENT

Booms and arms are welded with a low-stress, full-box section design. 6,150mm (20' 2"), 6,500mm (21' 4") Booms and 2,500mm (8' 2"), 3,200mm (10' 6"), 3,900mm (12' 10") Arms are available. Hyundai Bucket are all-welded, high-strength steel implements.

DIGGING FORCE

Boom	Length	6,150 (20' 2")		6,500 (21' 4")		Remark	
		mm (ft-in)	kg (lb)	mm (ft-in)	kg (lb)		
Arm	Length	2,500 (8' 2")		3,200 (10' 6")		Remark	
		mm (ft-in)	kg (lb)	mm (ft-in)	kg (lb)		
Bucket Digging Force	SAE	kN	228.5 (249.3)	201.0 (219.3)	201.0 (219.3)	[]: Power Boost	
		kgf	23,300 (25,420)	20,500 (22,360)	20,500 (22,360)		
	ISO	kN	259.9 (283.5)	228.5 (249.3)	228.5 (249.3)		
		kgf	26,500 (28,910)	23,300 (25,420)	23,300 (25,420)		
	Arm Crowd Force	SAE	kN	192.2 (209.7)	192.2 (209.7)		160.8 (175.4)
			kgf	19,600 (21,380)	19,600 (21,380)		16,400 (17,890)
Arm Crowd Force	ISO	kN	200.1 (218.2)	200.1 (218.2)	165.7 (180.8)		
		kgf	20,400 (22,250)	20,400 (22,250)	16,900 (18,440)		
			44,970 (49,050)	44,970 (49,050)	37,260 (40,650)		

Note : Boom weight includes arm cylinder, piping, and pin Arm weight includes bucket cylinder, linkage, and pin

STANDARD / OPTION

HYDRAULIC SYSTEM

	STD
INTELLIGENT POWER CONTROL (IPC)	
3-Power Mode, 2-Work Mode, User Mode	●
Variable Power Control	●
Pump Flow Control (Upgraded IPC)	●
Attachment Mode Flow Control	
Engine Auto Idle	●
Engine Auto Shutdown Control	●

CAB & INTERIOR

	STD
ISO STANDARD CABIN	
Cabin Lights (LED)	
Cabin Front Window Rain Guard	
Cabin Roof-Steel Cover	
Rise-Up Type Windshield Wiper	●
Radio / USB Player	●
Handsfree Mobile Phone System with USB	●
12 V Power Outlet (24 V DC to 12 V DC Converter)	●
Electric Horn	●
All-Weather Steel Cab with 360° Visibility	●
Safety glass - Tempered glass	●
Safety glass - Tempered glass with front laminated glass	
Sliding Fold-In Front Window	●
Sliding Side Window (LH)	●
Lockable Door	●
Hot & Cool Box	●
Storage Compartment & Ashtray	●
Transparent Cabin Roof-Cover	●
Sun Visor	●
Door and Cab Locks, One Key	●
Mechanical Suspension Seat With Heater	●
Pilot-Operated Slidable Joystick	●
Console Box Height Adjust System	●

AUTOMATIC CLIMATE CONTROL

Air Conditioner & Heater	●
Defroster	●

AUTOMATIC STARTING AID(AIR GRID HEATER) FOR WEATHER

Starting Aid (Air Grid Heater) for Cold Weather	●
---	---

CENTRALIZED MONITORING

8" LCD Display	●
Engine Speed or Trip Meter / Accel	●
Engine Coolant Temperature Gauge	●
Max Power	●
Low Speed / High Speed	●
Auto Idle	●
Overload warning with alarm	
Check Engine	●
Air Cleaner Clogging	●
Indicators	●
Eco Gauges	●
Fuel Level Gauge	●
Hyd. Oil Temperature Gauge	●
Fuel Warmer	●
Warnings	●
Communication Error	●
Low Battery	●
Clock	●

SEAT

Mechanical Suspension without Heater	●
Mechanical Suspension with Heater	
Adjustable Air Suspension without Heater	
Adjustable Air Suspension with Heater	

CABIN FOG (ISO 1,0262) LEVEL 2

FOG (Falling Object Guard)	Front & Tops Guard
	Top Guard

CABIN ROPS (ISO 1,2117-2)

ROPS (Roll Over Protective Structures)	●
--	---

SAFETY

	STD
Battery Master Switch	●
Rearview Camera	
AAVM (Advanced Around View Monitoring)	
Six Front Working Lights (4 Boom Mounted, 2 Front Frame Mounted)	●
Travel Alarm	●
Rear Work Beacon Lamp	
Automatic Swing Brake	●
Boom Holding System	●
Arm Holding System	●
Safety Lock Valve for Boom Cylinder with Overload Warning Device	
Safety Lock Valve for Arm Cylinder	
Swing Lock System	
Two Outside Rearview Mirror	●

OTHERS

	STD
Removable Clean-Out Dust Net for Cooler	●
Removable Washer Tank	●
Fuel Pre-Filter(1,000hr)	●
Fuel Warmer	●
Self-Diagnostics System	●
Hi MATE (Remote Management System)	
Batteries (2 × 12 V × 160 AH)	●
Fuel Filler Pump (50 ℓ/min)	
Single-Acting Piping Kit (Breaker, etc.)	
Double-Acting Piping Kit (Clamshell, etc.)	
Rotating Piping Kit	
Quick Coupler Piping	
Quick Coupler	
Boom Floating Control	
One Pedal Straight Travel System	
Accumulator for Lowering Work Equipment	●
Pattern Change Valve (2 Patterns)	
Tool Kit	

BOOMS

6.15 m, 20' 2"	
6.5 m, 21' 4"	●

ARMS

2.5 m, 8' 2"	
3.2 m, 10' 6"	●
3.9 m, 12' 10"	

UNDERCARRIAGE

Lower Frame Under Cover (Additional)	
Lower Frame Under Cover (Normal)	●

TRACK SHOES

Triple Grousers Shoes (600 mm, 24")	●
Triple Grousers Shoe (700 mm, 28")	
Triple Grousers Shoe (800 mm, 32")	
Triple Grousers Shoe (900 mm, 36")	
Double Grousers Shoe (600 mm, 24")	
Track Rail Guard	●
Full Track Rail Guard	

MEMO

MEMO